



## Contact Us

phone

203-778-5000

email

[dkim@kimindustries.com](mailto:dkim@kimindustries.com)

website

[kimindustries.com](http://kimindustries.com)



## FABRICATION

We are committed to providing you with the highest quality and best fitting removable insulation covers.

To make sure we provide exactly what you need, just give us a call, and we will discuss the design process.

Kim Industries, Inc.  
47 Castle Meadow Road  
Newtown, CT 06470



# FABRICATION FACILITY

Unlike most removable insulation, Kim Industries covers fit the best because they are sewn in the actual shape of the equipment, whether that is a single valve or an entire piping system. By custom-engineering every cover for each customer, our products will fit your system perfectly.

Our state of the art fabrication facility is located in Oxford, Connecticut and is staffed by an experienced team of full-time fabricators. We can quickly and accurately produce any type of removable cover.

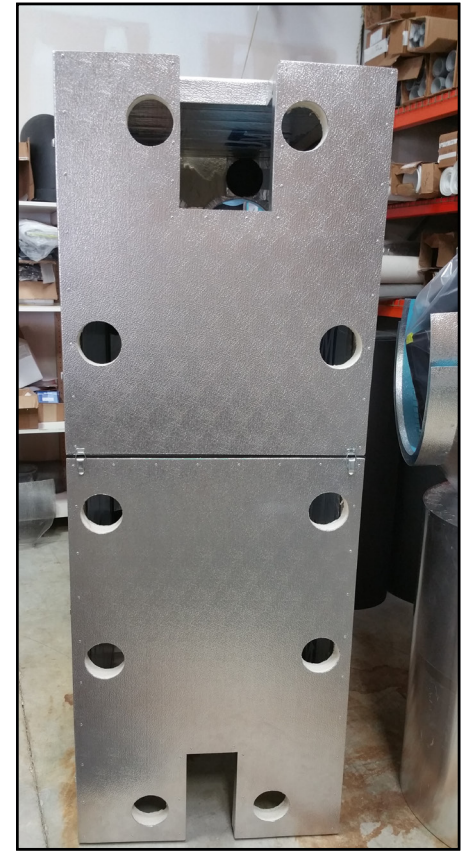

# Plate & Frame Exchanger

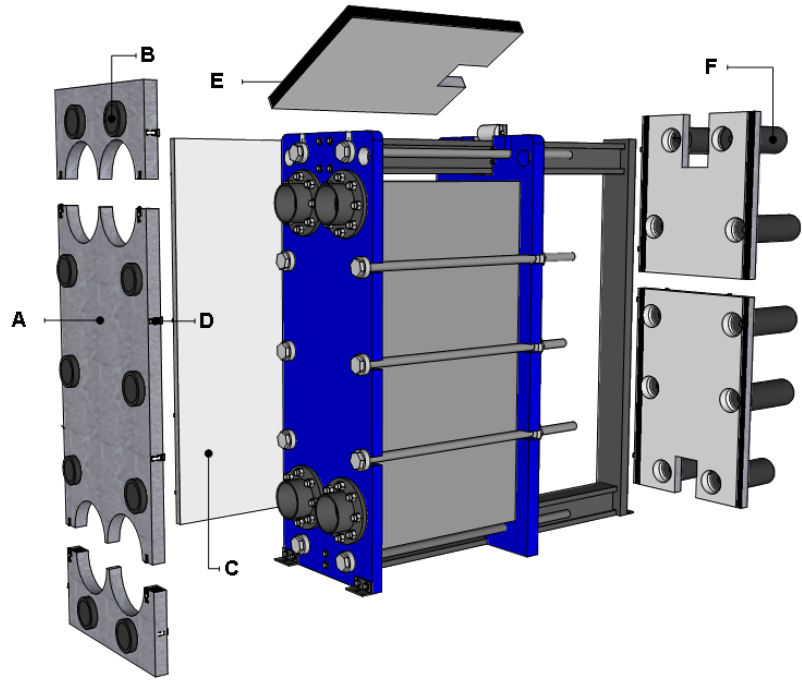

**A** Embossed ridged aluminum shell

**B** EPDM rubber insulation covers for access to bolts

**C** Polyisocyanurate foam insulation

**D** Latch style buckles for ease of application and removal for maintenance

**E** Rubber insulation tape for an airtight seal between panels

**F** Rubber pipe insulation for exposed exchanger rod

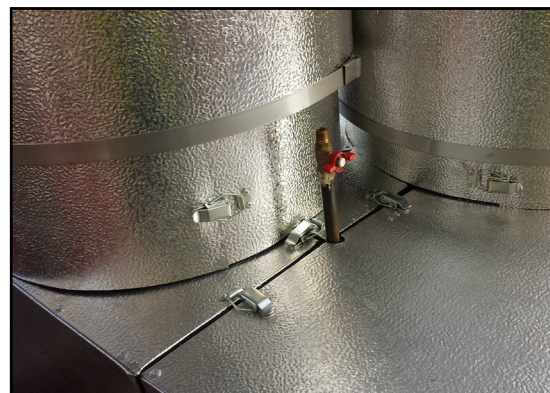
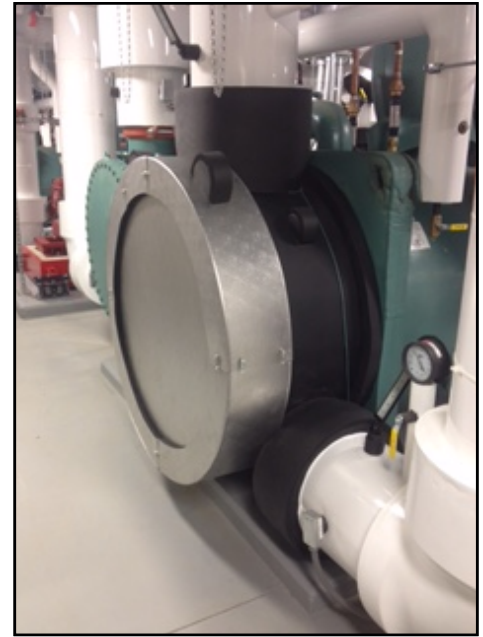

## Inline Pump Box

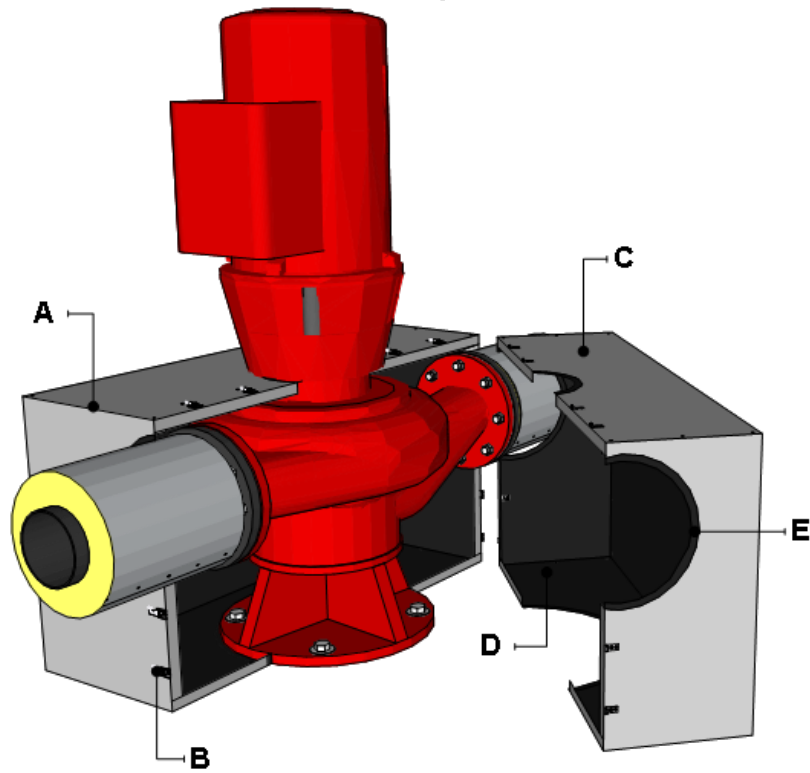

**A** Aluminum rivet fasteners for a sturdy box with a clean look

**B** Latch style buckles for ease of installation and removal for maintenance

**C** Ridged aluminium shell for strength and durability

**D** EPDM Rubber insulation lines the box on all sides

**E** Exposed rubber beyond metal for a tight seal against pipe insulation

